

العمارة فى فجر المسيحية

Early Christian Architecture & Byzantine Architecture

Dr. Kamal Elgabalawy

THE REFERENCES TO MULTIPLE SOURCES ARE TEXT & FIGURES

(SKETCHES, DRAWINGS, PICTURES, PHOTOS,...ETC.)

ALL THE RIGHTS BELONG TO ORIGINAL AUTHORS

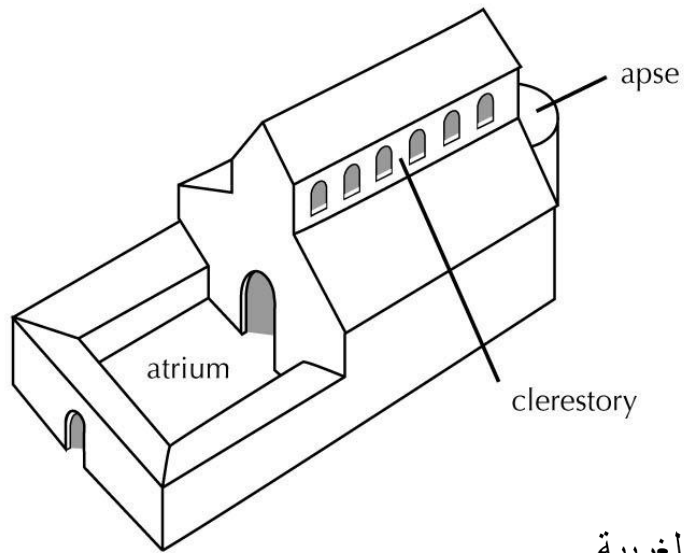

الامبراطورية الغربية
basilica-plan church

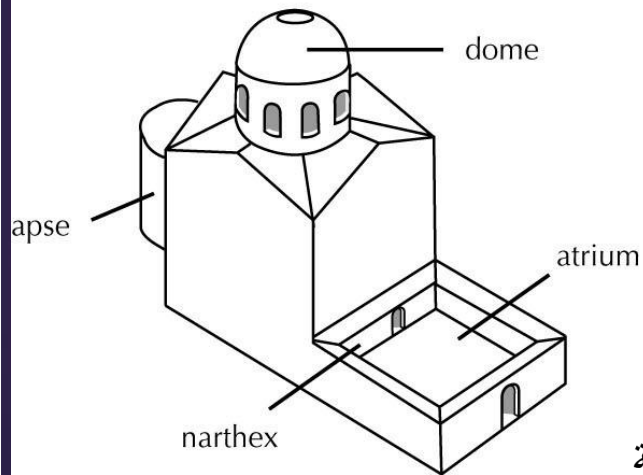
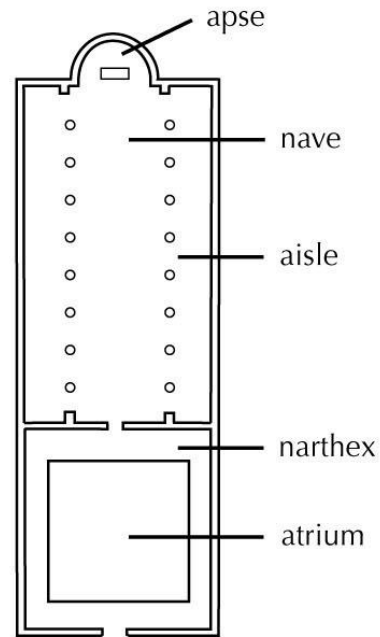

الامبراطورية الشرقية
central-plan church

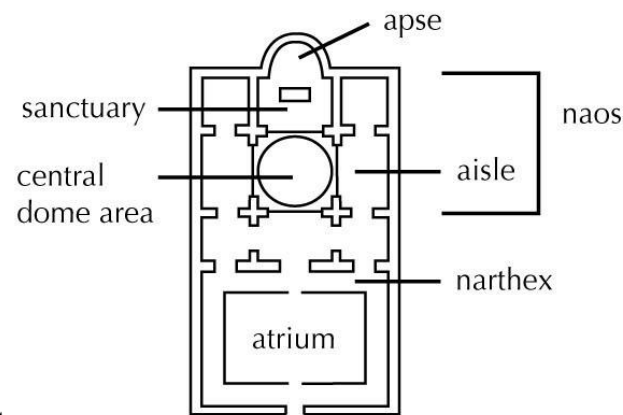

مكونات الكنيسة:

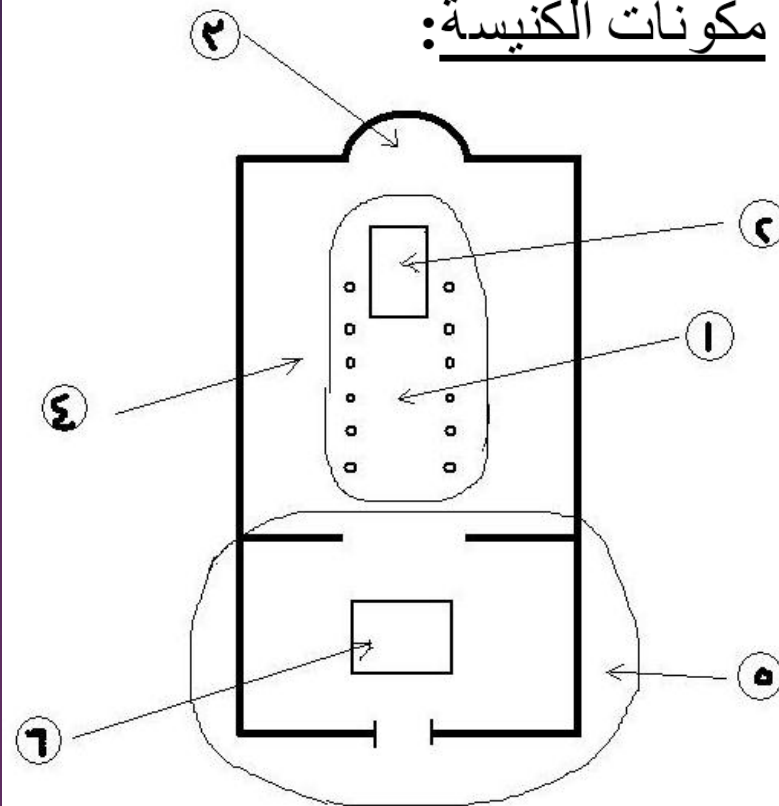

- ١- الصحن الرئيسي (nave)
- ٢- منطقة المرتلين (chair)
- ٣- منطقة القبلة (sanctuary)
- ٤- الممرات الجانبية (aisles)
- ٥- رواق الحماية (narthex)
- ٦- الفناء الداخلى (atrium)

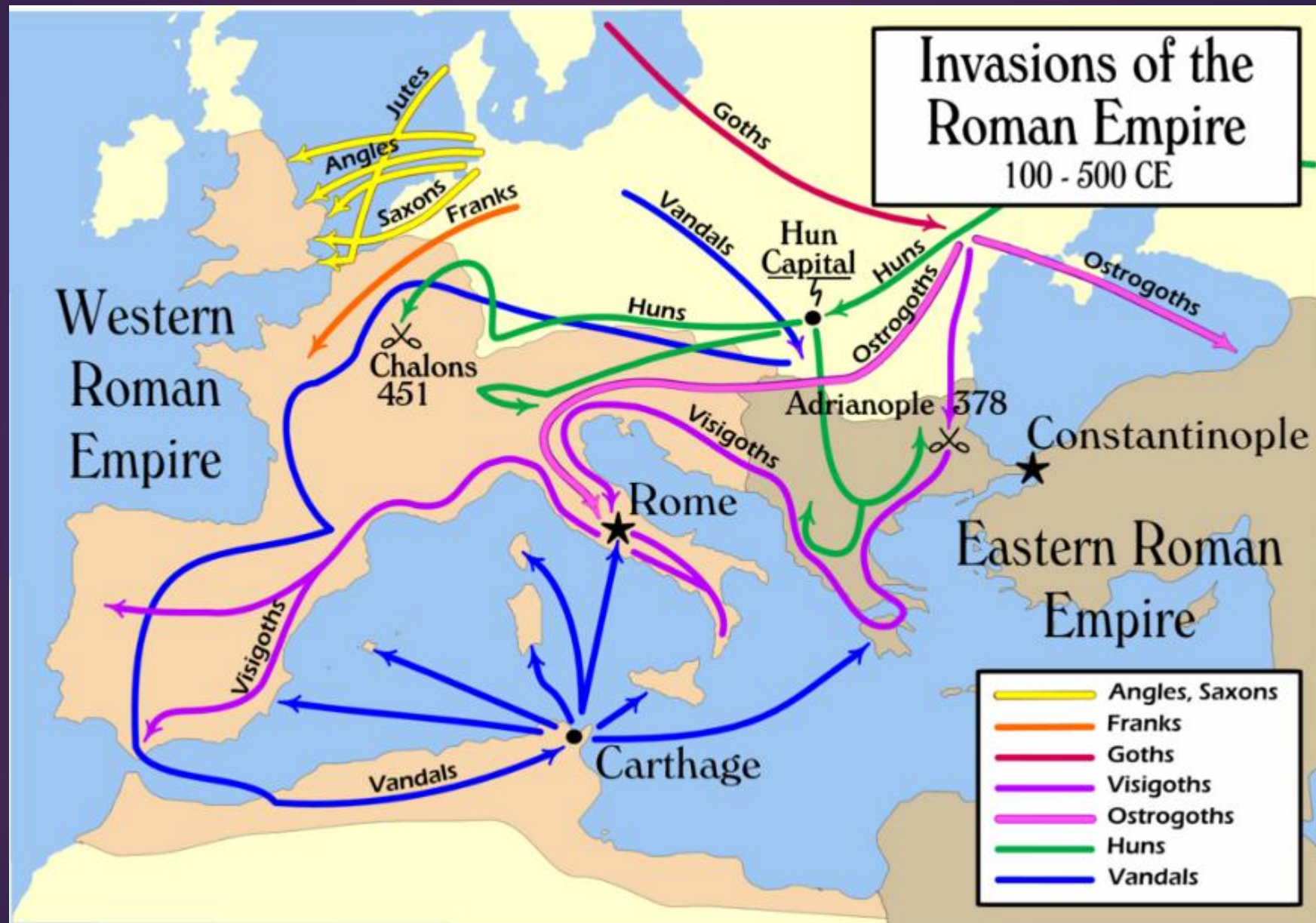

EARLY CHRISTIAN ARCHITECTURE

- Time period: 3rd-7th centuries
- The term Early Christian refers to the architecture related to Christian religion.
- After Christianity is recognized receiving official approval from Roman Empire. Christians begin constructing religious structures adapted from Roman prototypes.

BYZANTINE

- Time Period: 330-1453 CE
- The Byzantine or Eastern Roman Empire maintains Roman culture and buildings tradition before and after the fall of the city of Rome in 476 CE. - Imperial patronage encourages the Christian religion and the buildings of new structure. Orthodox Byzantine churches are domed and centrally planned with distinctive iconographic mosaic.

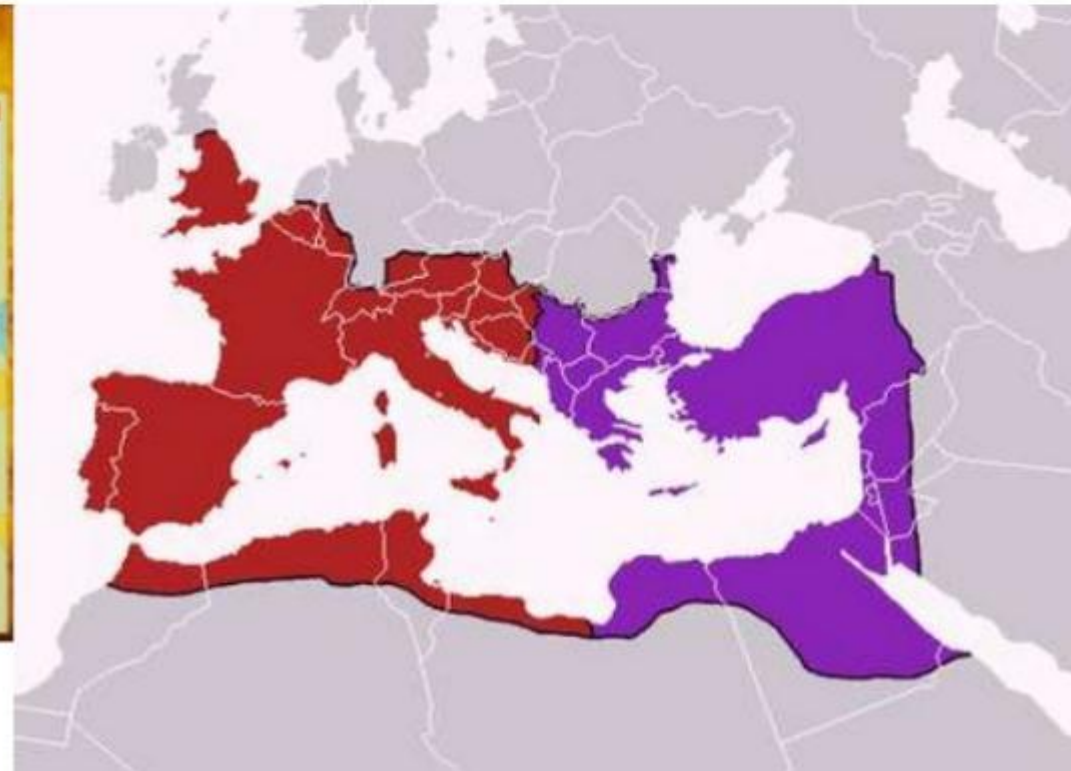
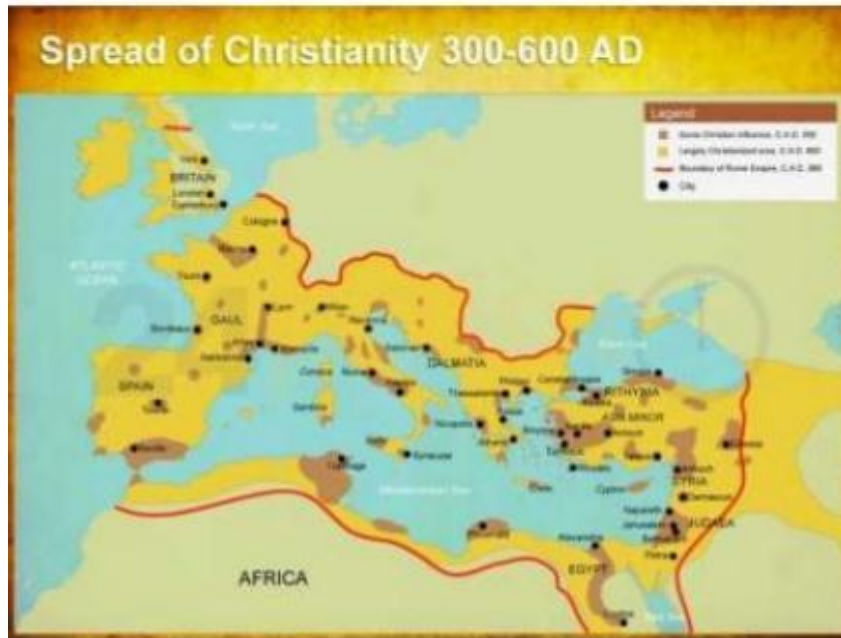

COMPARISON BETWEEN EARLY CHRISTIAN AND BYZANTINE ARCHITECTURE

Student: Nguyen Tuan Viet – 13KTT

Early Christian vs. Byzantine Architecture		
	Early Christian	Byzantine
Where in Europe:	West.	East.
Capital:	Rome.	Byzantium/Constantinople.
Language:	Latin.	Greek.
Relationship between church and state:	Separation between church and state.	Union between church and state.
Type of Christianity:	Catholic.	Orthodox.
Art:	Catacomb paintings, mosaics.	Mosaics, icons.
Architecture:	Basilica-plan church.	Central-plan church.
Roof:	Flat timber.	Domed.
Roof support:	Post and lintel.	Pendentives.
Example:	S. Apollinare.	Hagia Sophia.
Time:	3 rd -7 th century CE	330-1453 CE

(Source: http://www2.palomar.edu/users/mhudelson/StudyGuides/ECvsByz_WA.html)

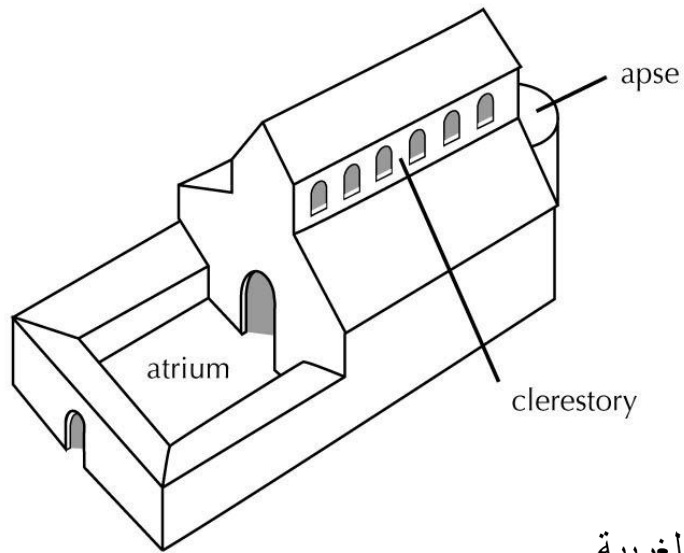

الامبراطورية الغربية
basilica-plan church

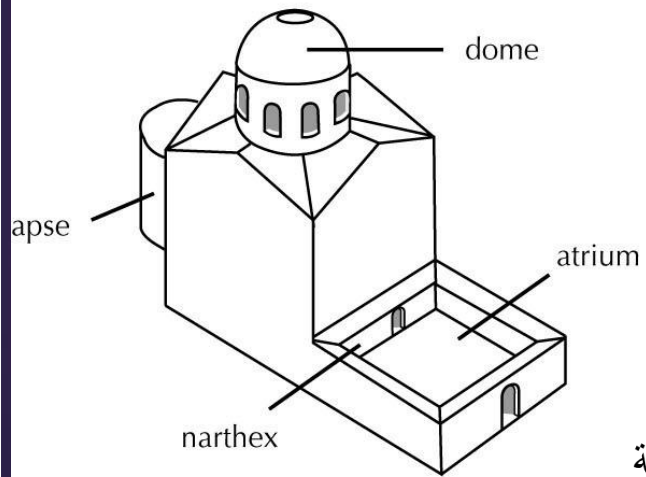
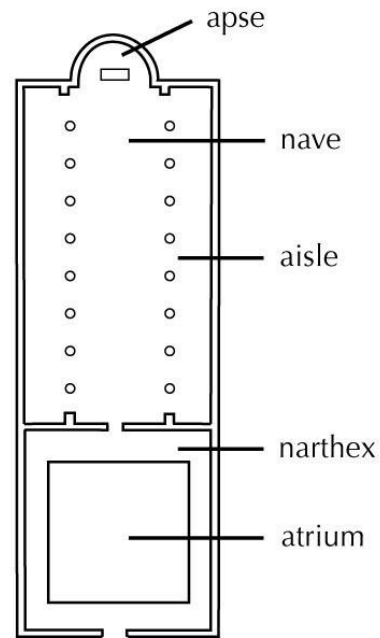

الامبراطورية الشرقية
central-plan church

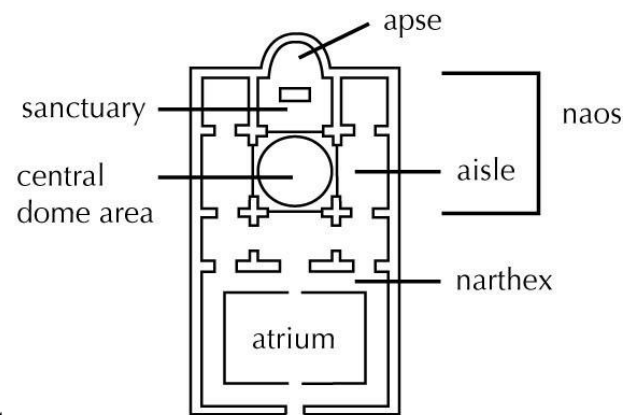

مكونات الكنيسة:

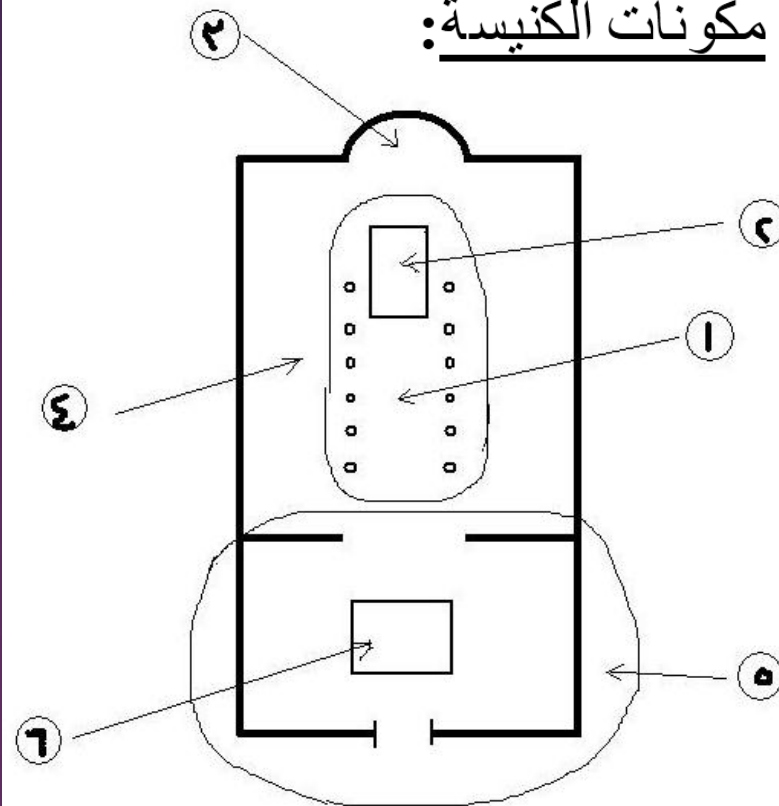

- ١- الصحن الرئيسي (nave)
- ٢- منطقة المرتلين (chair)
- ٣- منطقة القبلة (sanctuary)
- ٤- الممرات الجانبية (aisles)
- ٥- رواق الحماية (narthex)
- ٦- الفناء الداخلى (atrium)

St. Clemente, Rome

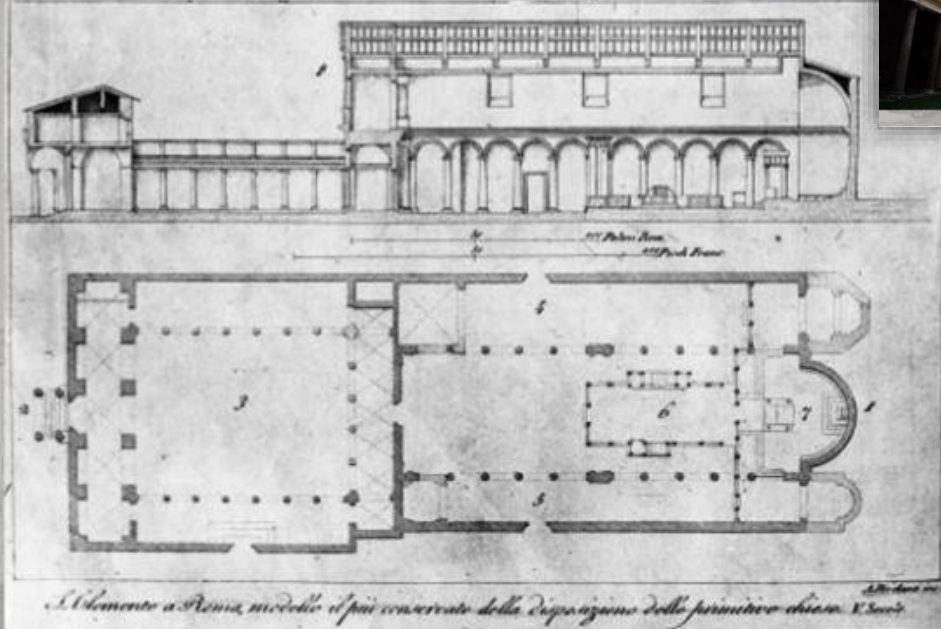

- 1 - Apse
- 2 - Portico
- 3 - Central Atrium
- 4 - Men's Aisle
- 5 - Ladies Aisle
- 6 - Choir with Gospel & Epistle Ambo
- 7 - Altar



S.CLEMENTE, ROME

Basilica di San Clemente. Rome

من أهم الأعمال المعمارية في عمارة فجر المسيحية

• كنيسة سانت كلمينت ، روما، اوائل القرن الثاني عشر

XII-CENTURY BASILICA

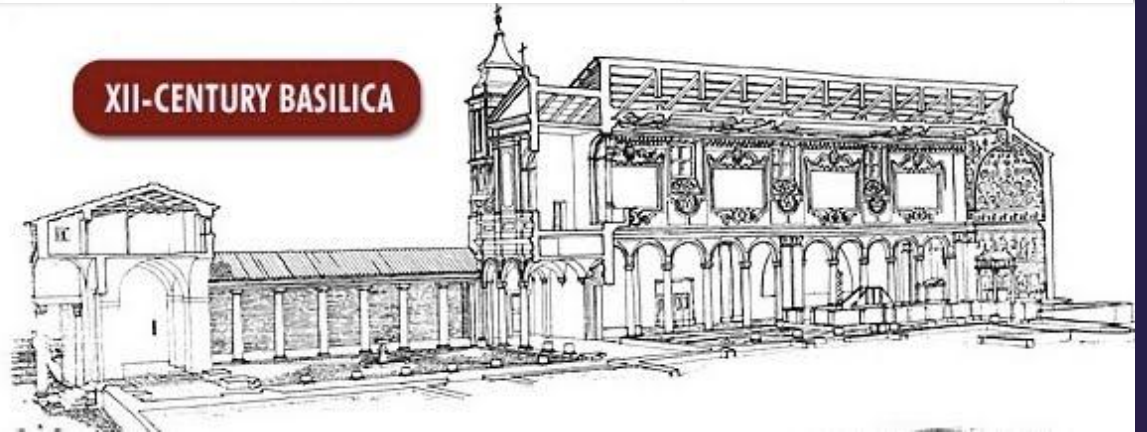

(St. Clement's Church) (1099 - 1108)

It was built in Rome in 313 AD but was completely burned down and rebuilt in 1099 AD, but the reconstruction was the same.

A portion has been added to the church to defend it. The bell tower was added to the church in (1099 - 1108).

The candlestick column was also used for the symbolic expression, as the pillar was burning to light the church.

In the chanting area there is a pillar that does not hold anything, which is a candlestick for lighting due to the lack of electricity



DOME

ACRADE

ALTAR

CHOIR WITH GOSPEL & EPISTLE AMBO

St. Clemente, Rome

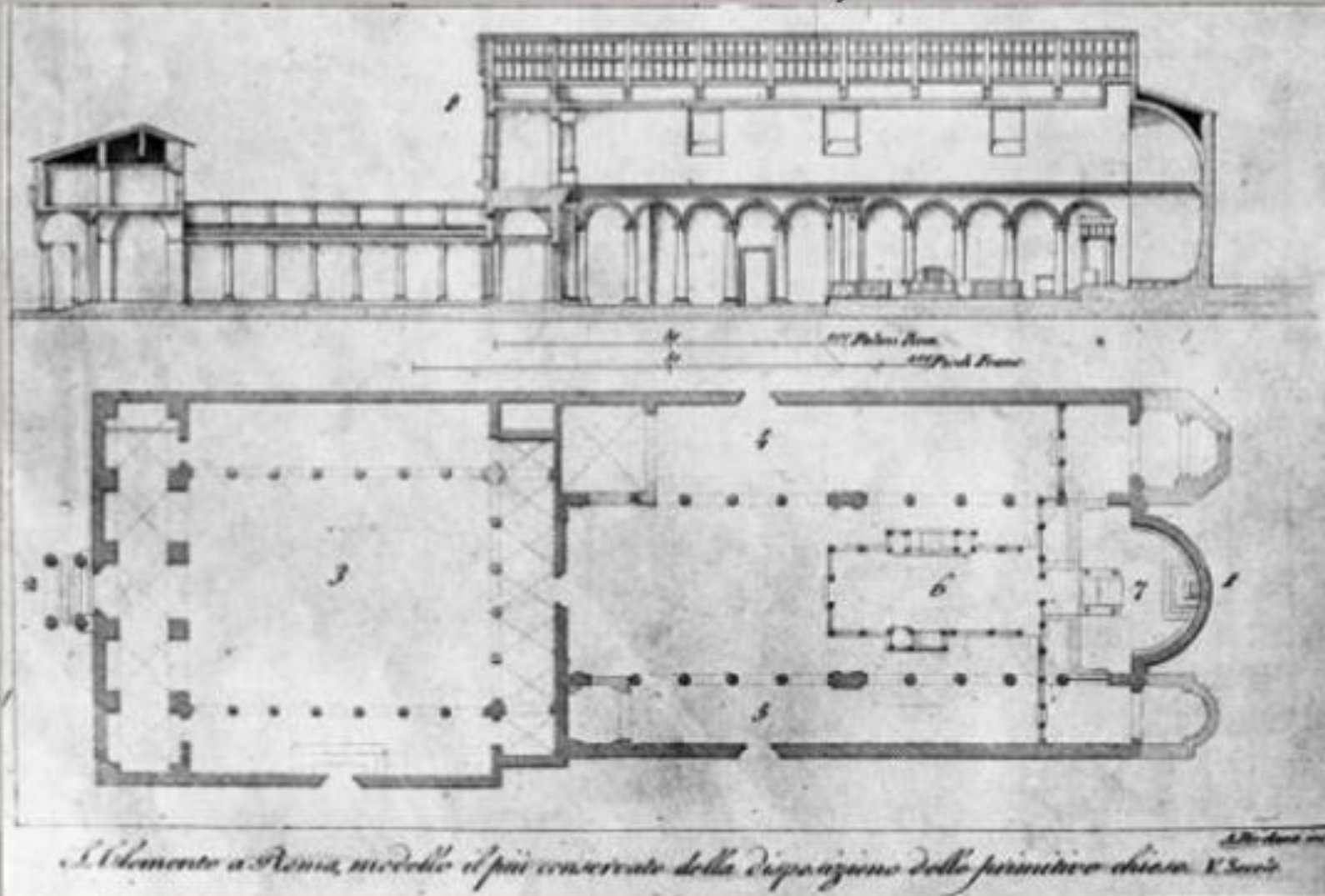

- 1 – Apse 2 – Portico 3 – Central Atrium 4 – Men's Aisle
5 – Ladies Aisle 6 – Choir with Gospel & Epistle Ambo 7 – Altar

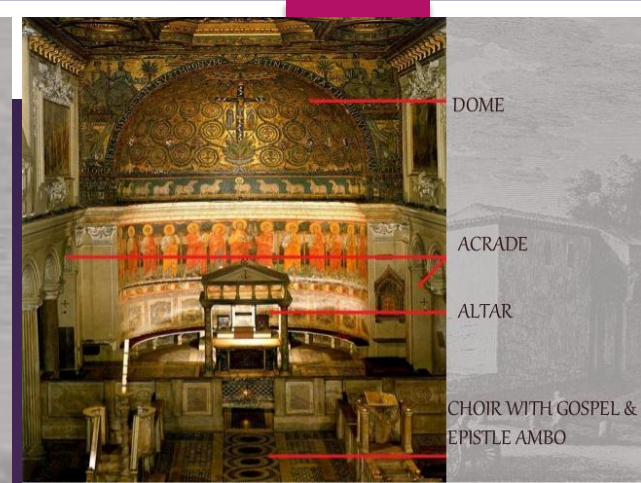

**Basilica di San
Clemente.
Rome**

St. Clemente, Rome

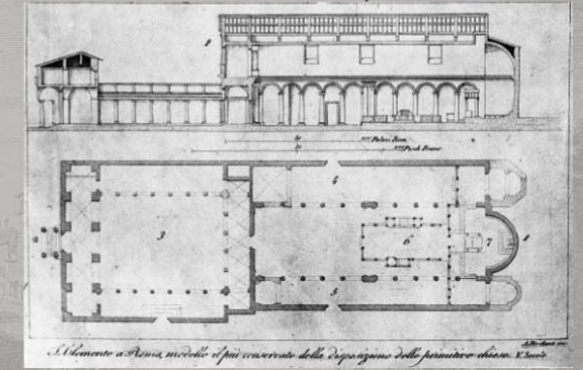

- 1 - Apse
- 2 - Portico
- 3 - Central Atrium
- 4 - Men's Aisle
- 5 - Ladies Aisle
- 6 - Choir with Gospel & Epistle Ambo
- 7 - Altar



Basilica di San Clemente, Rome

DOME

ACRADE

ALTAR

CHOIR WITH GOSPEL & EPISTLE AMBO

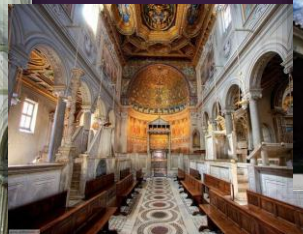
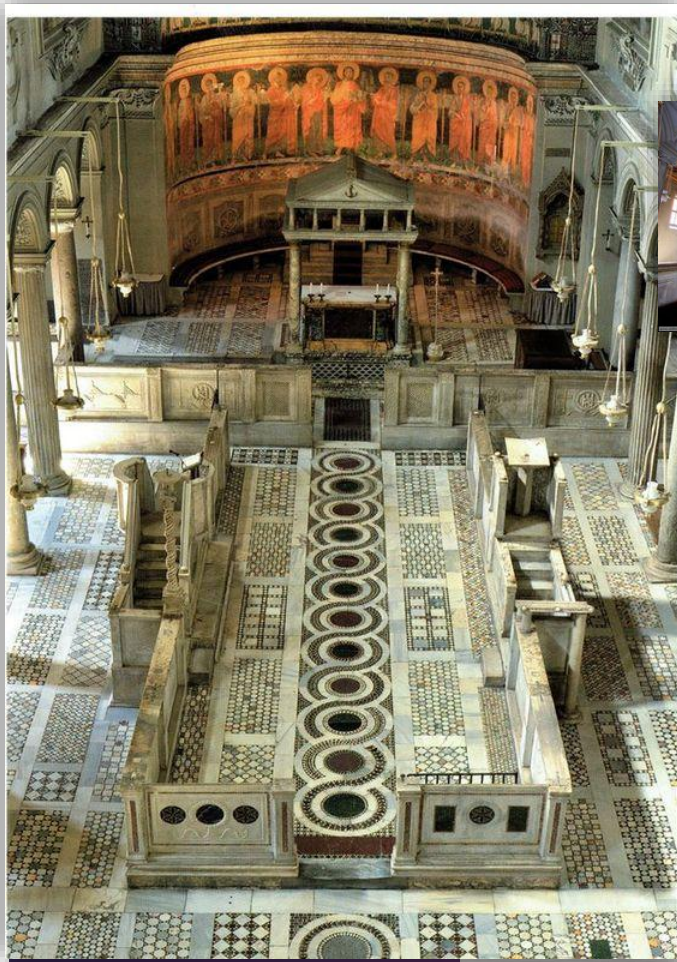

من أهم الأعمال المعمارية في عمارة فجر المسيحية

• كنيسة سانت كلمينت ، روما، اوائل القرن الثاني عشر

S.CLEMENTE, ROME

Basilica di San Clemente. Rome

XII-CENTURY BASILICA

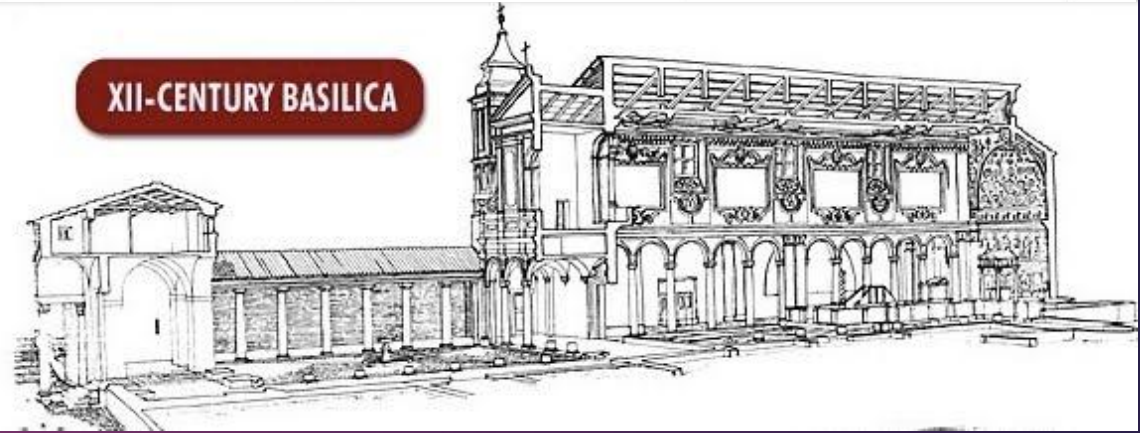

(St. Clement's Church) (1099 - 1108)



MOSAIC WORK

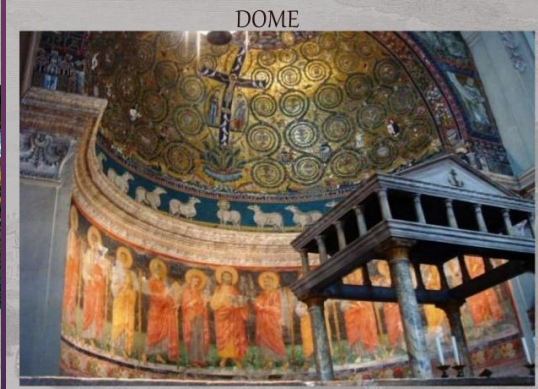

DOMES

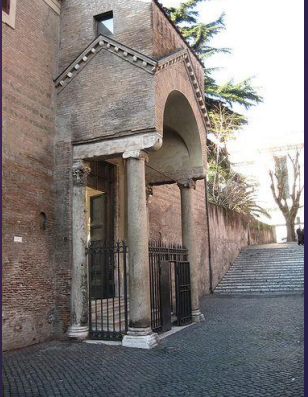

1- St Peters Basilica, Rome . م ٣٣٠ الفاتيكان - (كنيسة سانت بيتر أو القديس بطرس)

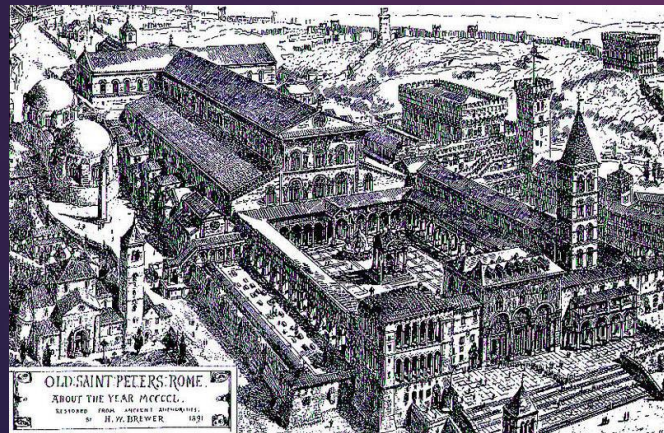
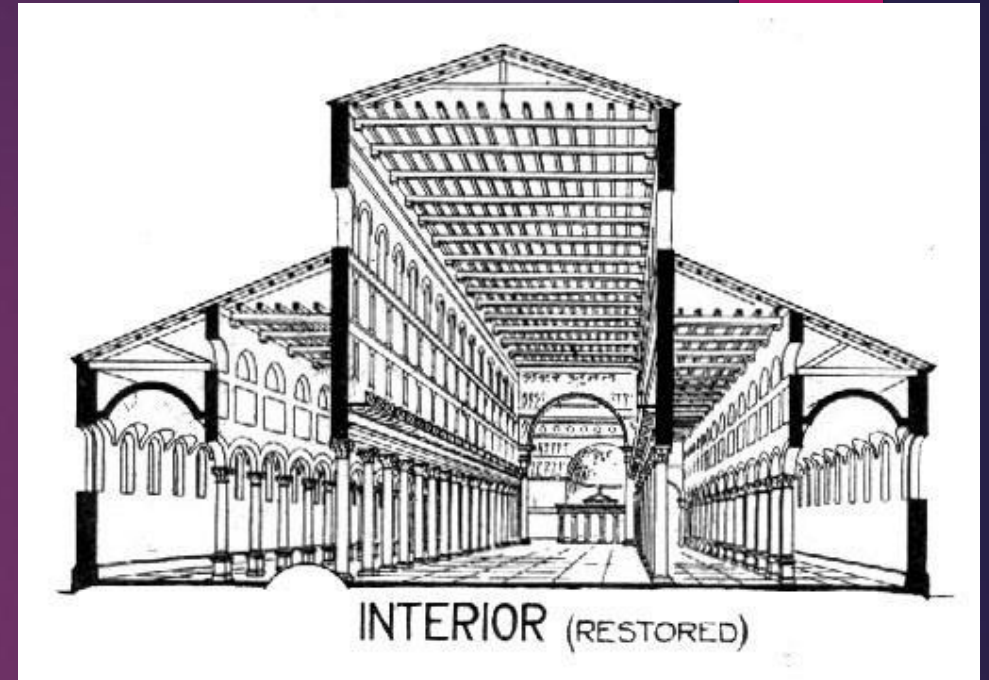
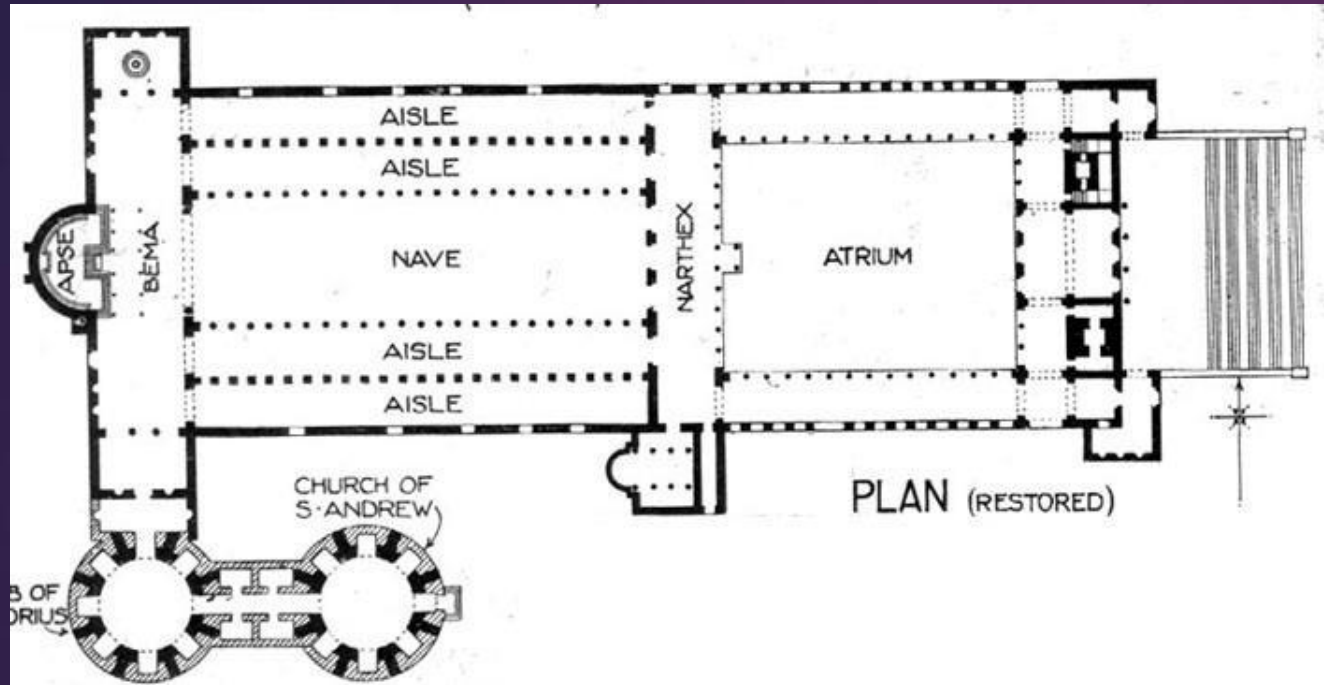

This church has a system (Double Aisle System)

This building has no area for the apostles and it is now replaced (Bema).
It is a cross pass dedicated to the two recliners
There are also external windows for lighting and ventilation

A bell tower was added to the church
The church was burned and the Vatican Church was built in 1600

1- St Peters Basilica, Rome . م ٣٣٠ - الفاتيكان (كنيسة سانت بيتر أو القديس بطرس)

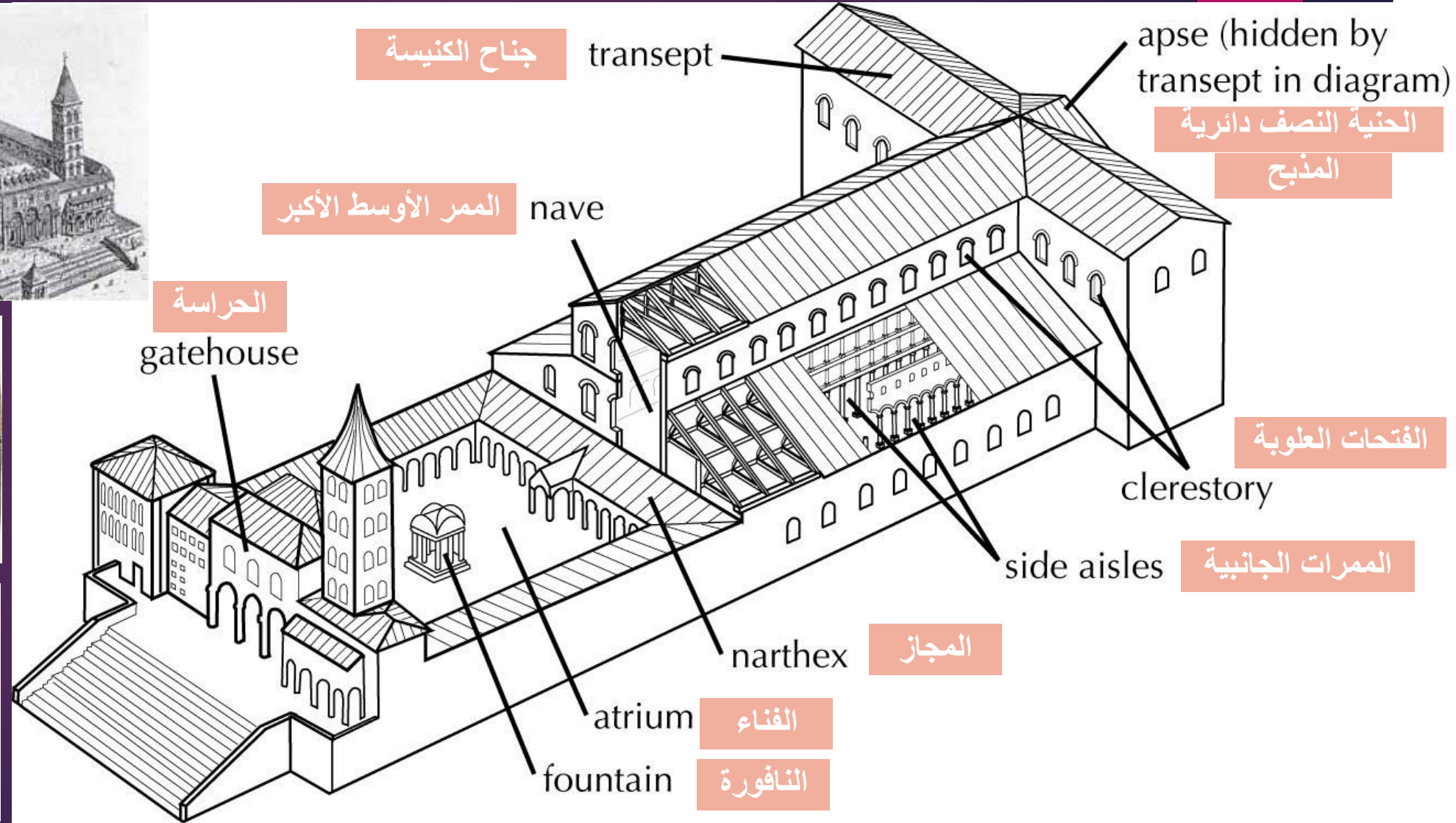
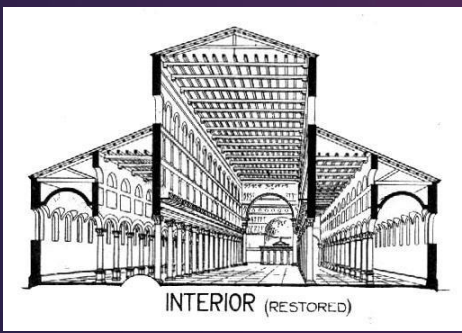
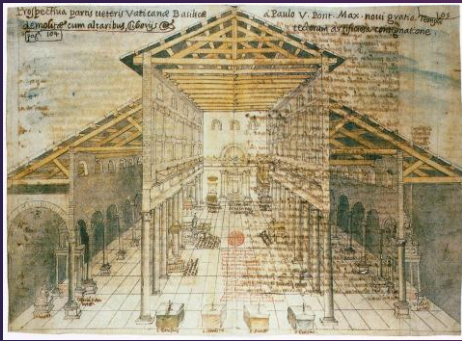
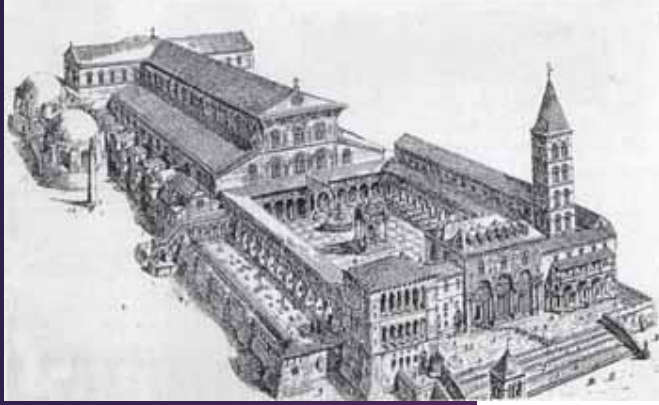

العمارة فى فجر المسيحية

Thank You

Early Christian Architecture
& Byzantine Architecture

Dr. Kamal Elgabalawy

THE REFERENCES TO MULTIPLE SOURCES ARE TEXT & FIGURES

(SKETCHES, DRAWINGS, PICTURES, PHOTOS,...ETC.)

ALL THE RIGHTS BELONG TO ORIGINAL AUTHORS